

University of Baghdad
Computer Engineering Department
4th Class
Subject: Internet Technology
2017-2018

Dr. Mustafa I. Salman



Lecture 1

Introduction

THE INTERNET DEFINITION

- The Internet is a global system of interconnected computer networks that use the standard Internet Protocol Suite (TCP/IP) to serve billions of users worldwide. It is a network of networks that consists of millions of private, public, academic, business, and government networks, of local to global scope, that are linked by a broad array of electronic, wireless and optical networking technologies. The Internet carries a vast range of information resources and services, such as the inter-linked hypertext documents of the World Wide Web (WWW) and the infrastructure to support electronic mail.

A Key Milestone of Birth of Internet

- In 1967, The Advanced Research Projects Agency (ARPA) in ARPA presented its ideas for ARPANET, a small network of connected computers. The idea was that each host computer (not necessarily from the same manufacturer) would be attached to a specialized computer, called an interface message processor (IMP). The IMPs, in turn, would be connected to each other.
- By 1969, ARPANET was a reality. Four nodes, at the University of California at Los Angeles (UCLA), the University of California at Santa Barbara (UCSB), Stanford Research Institute (SRI), and the University of Utah, were connected via the IMPs to form a network. Software called the Network Control Protocol (NCP) provided communication between the hosts.

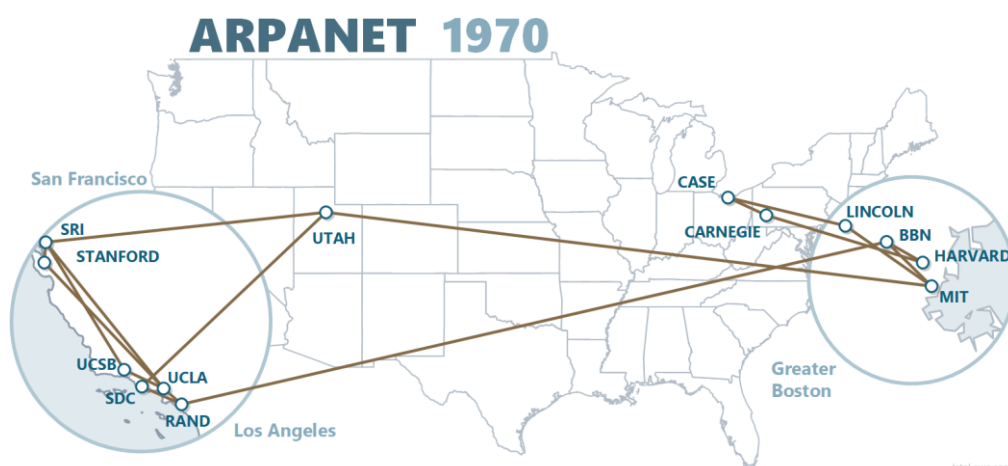

Internet Administration

- The internet operated by various agencies, non-profit organizations, and for-profit corporations.

The diagram below illustrates the major organizations responsible for the administration and oversight of the Internet at the current time.

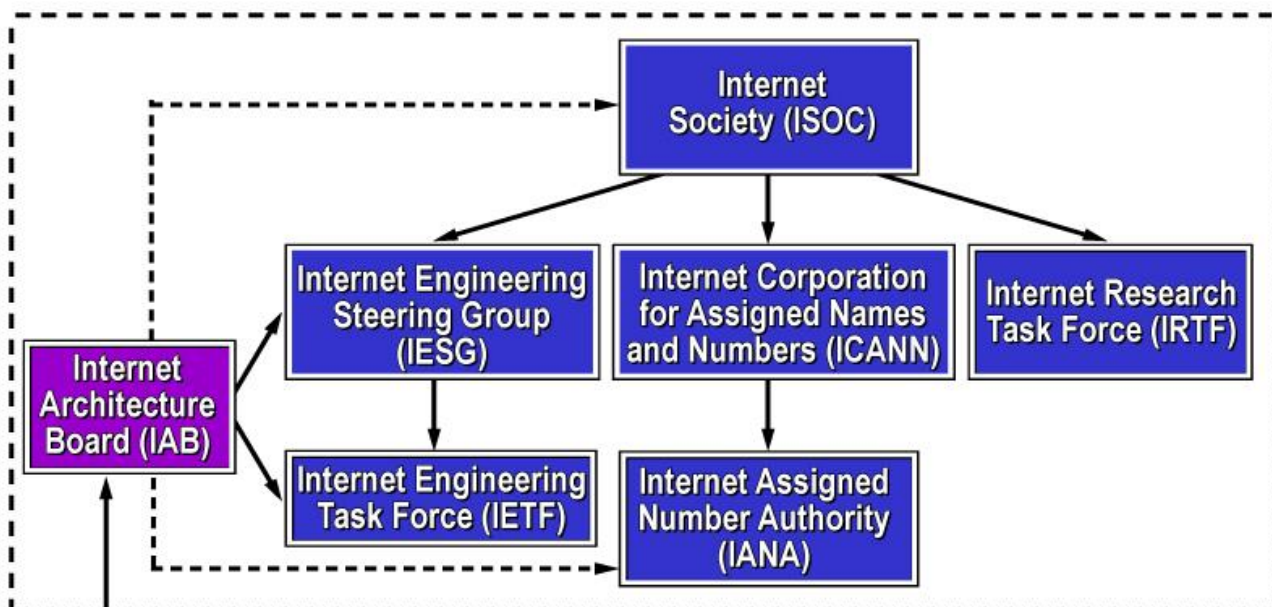

- *Internet Society (ISOC):* It is the group responsible for oversight of the Internet on a worldwide basis. ISOC is a board comprised of 15 individuals from around the world. ISOC is headquartered in Reston, Virginia; their web site is www.isoc.org.
- *ISOC oversees the activities of the Internet Engineering Steering Group (IESG), the Internet Corporation for Assigned Names and Numbers (ICANN) and the Internet Research Task Force (IRTF).*

- The IESG oversees the Internet Engineering Task Force (IETF), which is the organization responsible for maintenance of the Internet standards, or RFC.
- The major function of ICANN is to coordinate the assignment of Internet domain names and IP addresses. ICANN handles Internet domain name assignment via designated registries.
- The Internet Assigned Number Authority (IANA) oversees the actual distribution of IP addresses and other important registered numbers for the Internet.
- The Internet Architecture Board (IAB) plays an advisory role to many of the other Internet oversight groups.

Internet vs. Intranet and Extranet

- The Internet is a packet-switching network with a distributed mesh topology. Information travels in packets across a network that consists of multiple paths to a destination. Networks are interconnected with routers, which forward packets along paths to their destinations. The mesh topology provides redundant links. If a link fails, packets are routed around the link along different paths.

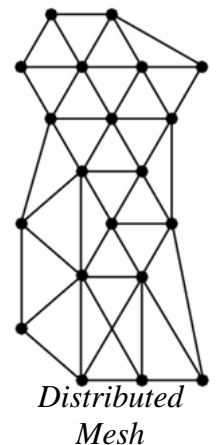

- In order for a network to be connected to the Internet, the network must send and retrieve data by using TCP/IP (Transmission Control Protocol/Internet Protocol) and related protocols.
- The Intranet is an internal client-Server network that uses the same software technology as the Internet – TCP/IP – for its own internal use.
- An intranet is generally based on a three-tier architecture, comprising:
 1. clients (generally Web browsers);
 2. one or several application web servers (middleware)

3. a database server.

An intranet

All computers communicate using TCP/IP but none have connections to the Internet

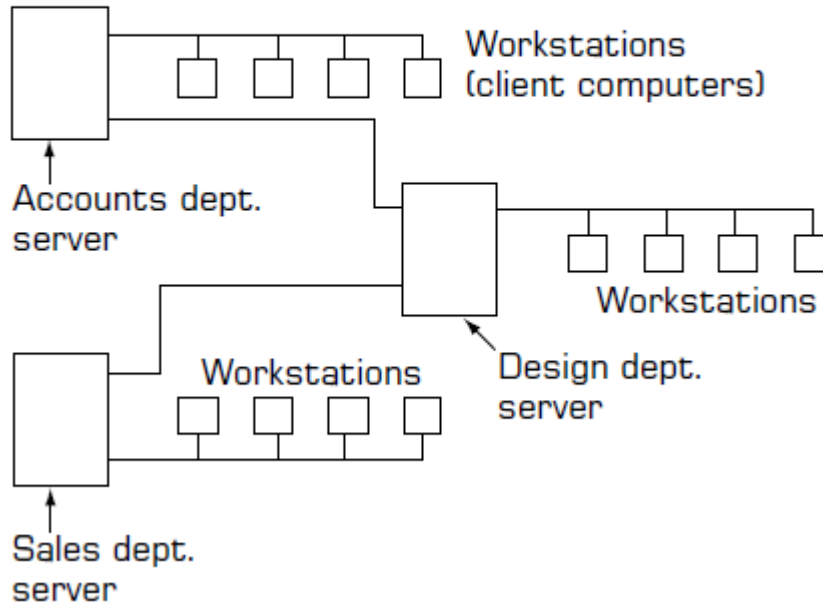

- An Extranet is an intranet that is connected to the Internet but in such a way that some additional security has been built into the connections.

An extranet

Internal intranet technologies

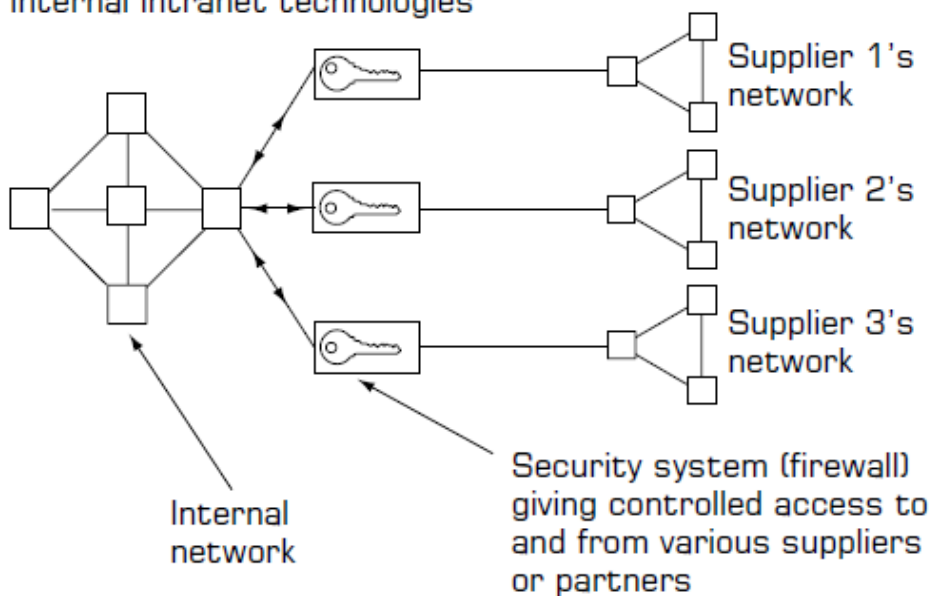

Internet Architecture and Backbone

- The Internet is hierarchical in structure. At the top are the very large national Internet service providers (ISP) that are responsible for large Internet networks. These national ISPs connect together and exchange data at Network Access Points (NAP). See the figure below.

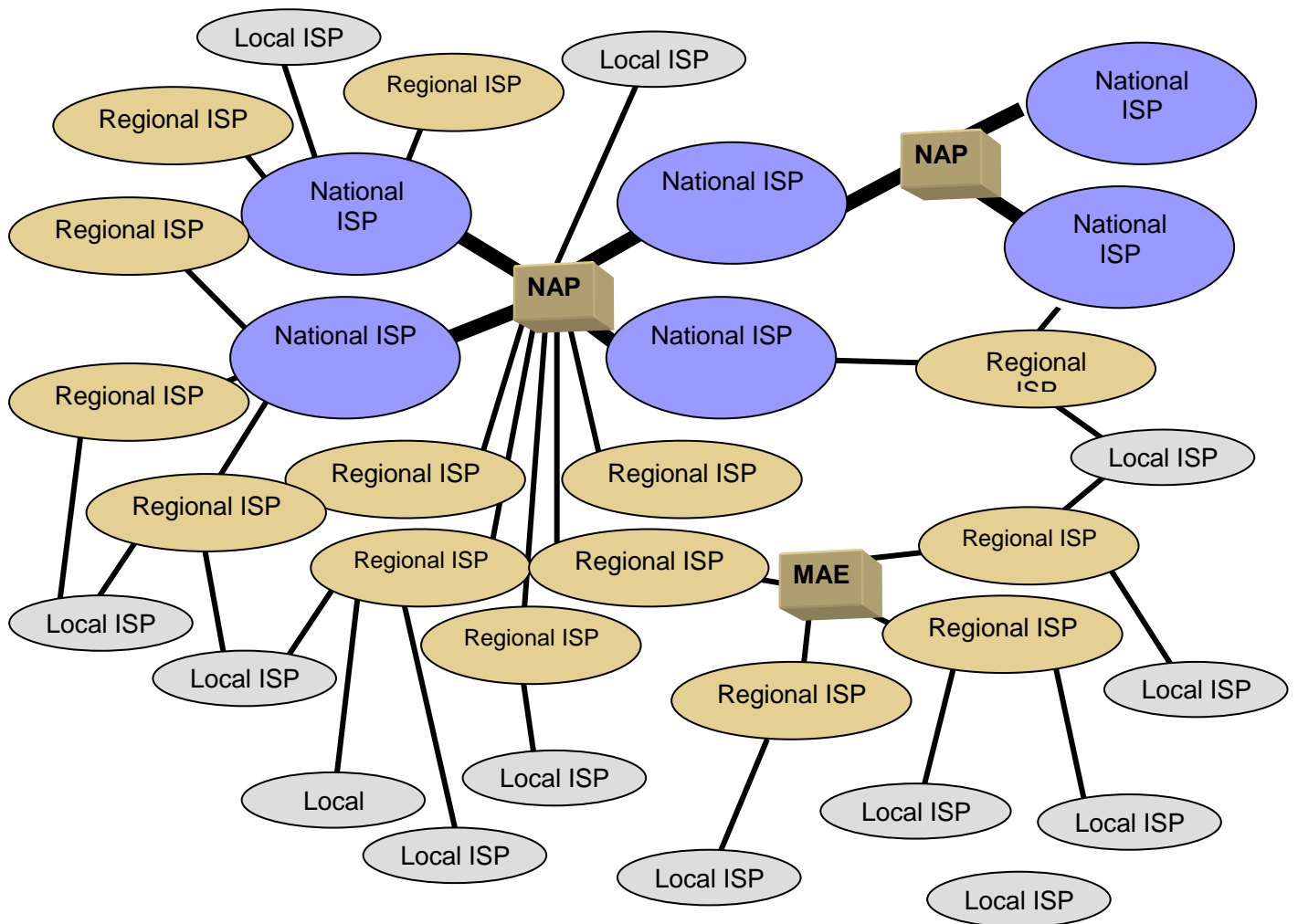

- NAPs were originally designed to connect only national ISPs. These national ISPs in turn provide services for their customers and also to regional ISPs. These regional ISPs rely on the national ISPs to transmit their messages to national ISPs in other countries. Regional ISPs in turn provide services to their customers and to local ISPs who sell Internet access to individuals.

- As the number of ISPs grew, a new form of network access point called a metropolitan area exchange (MAE) has emerged. MAEs are smaller versions of NAPs and typically link a set of regional ISPs whose networks come together in major cities.
- ISPs at the same level do not charge each other for transferring messages they exchange across a NAP or MAE. That is, a national ISP does not charge another national ISP to transmit its messages and a regional ISP does not charge another regional ISP. This is called peering.

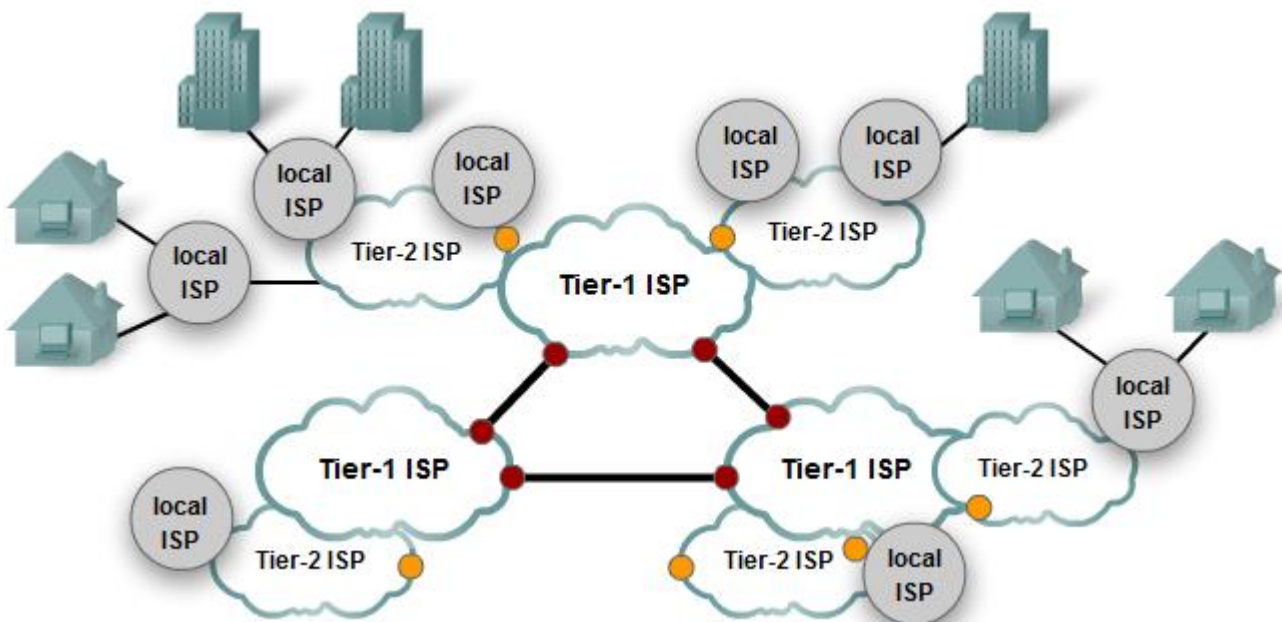

- It is peering that makes the Internet work and has led to the belief that the Internet is "free." This is true to some extent, but higher level ISPs normally charge lower level ISPs to transmit their data (e.g., a national will charge a regional and a regional will charge a local). And of course, a local ISP will charge individuals like us for access!

Connecting to an ISP

- Each ISP has one or more points-of-presence (POP). A POP is simply the place at which the ISP provides services to its customers.
- In order to connect into the Internet, a customer must establish a circuit from his or her location into the ISP POP. For individuals, this is often done using a modem over a traditional telephone line using the PPP protocol (see the figure below). This call connects to the modem pool at the ISP and from there to a remote access server (RAS) which checks the (user ID) and (password) to make sure the caller is a valid customer. Once logged in, the user can begin sending TCP/IP packets from his or her computer over the phone to the RAS, which then forwards them to the backbone network at the POP.

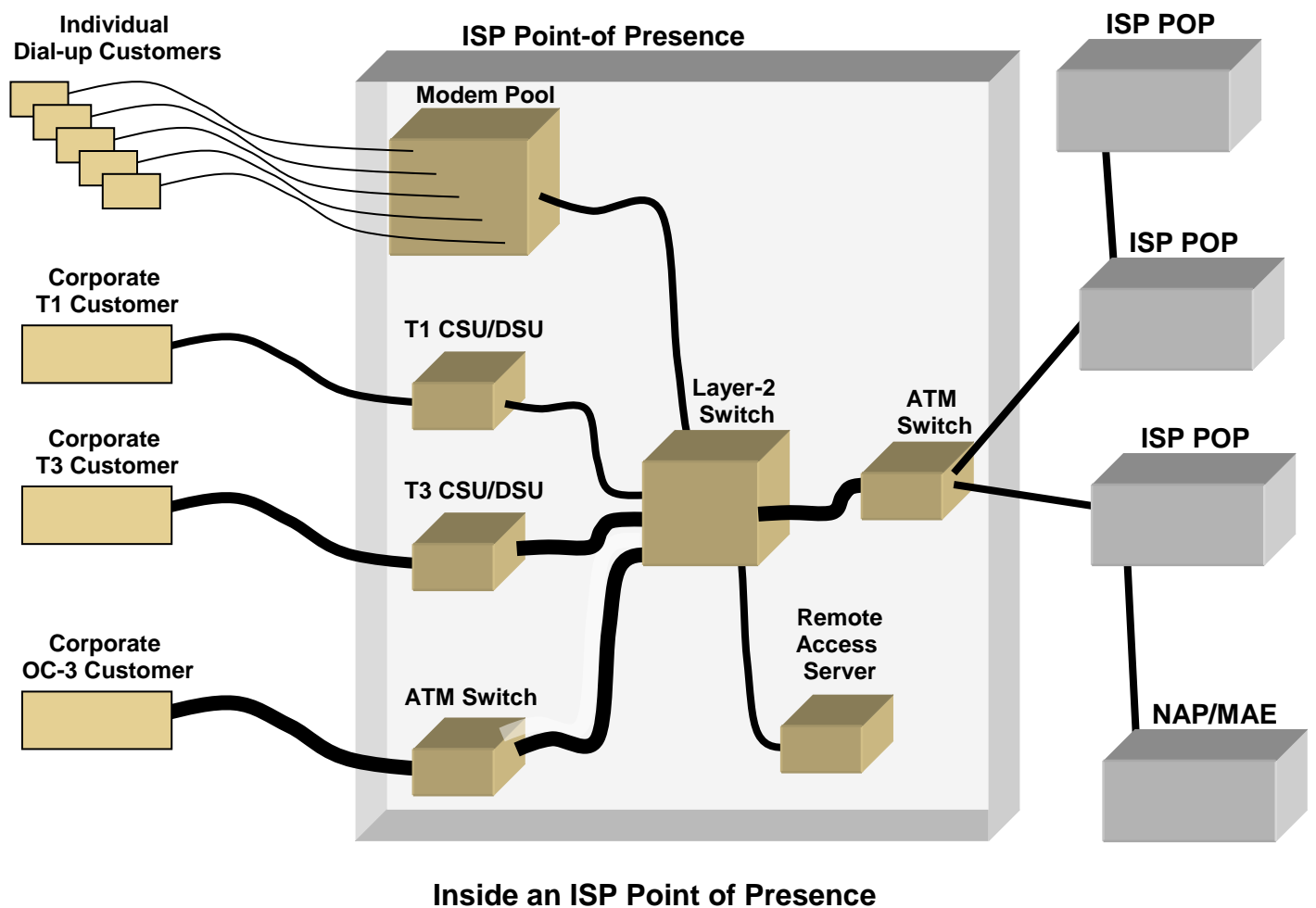

From the ISP to the NAP/MAE

- Any messages destined for other customers of the same ISP would flow within the ISP's own network. In most cases, the messages are destined outside of the ISP's network, and thus must flow through it to the nearest NAP/MAE and from there into some other ISP's network.
- The figure below shows the connection from the local ISP to the NAP. From there packets are routed to the next higher level of ISP.

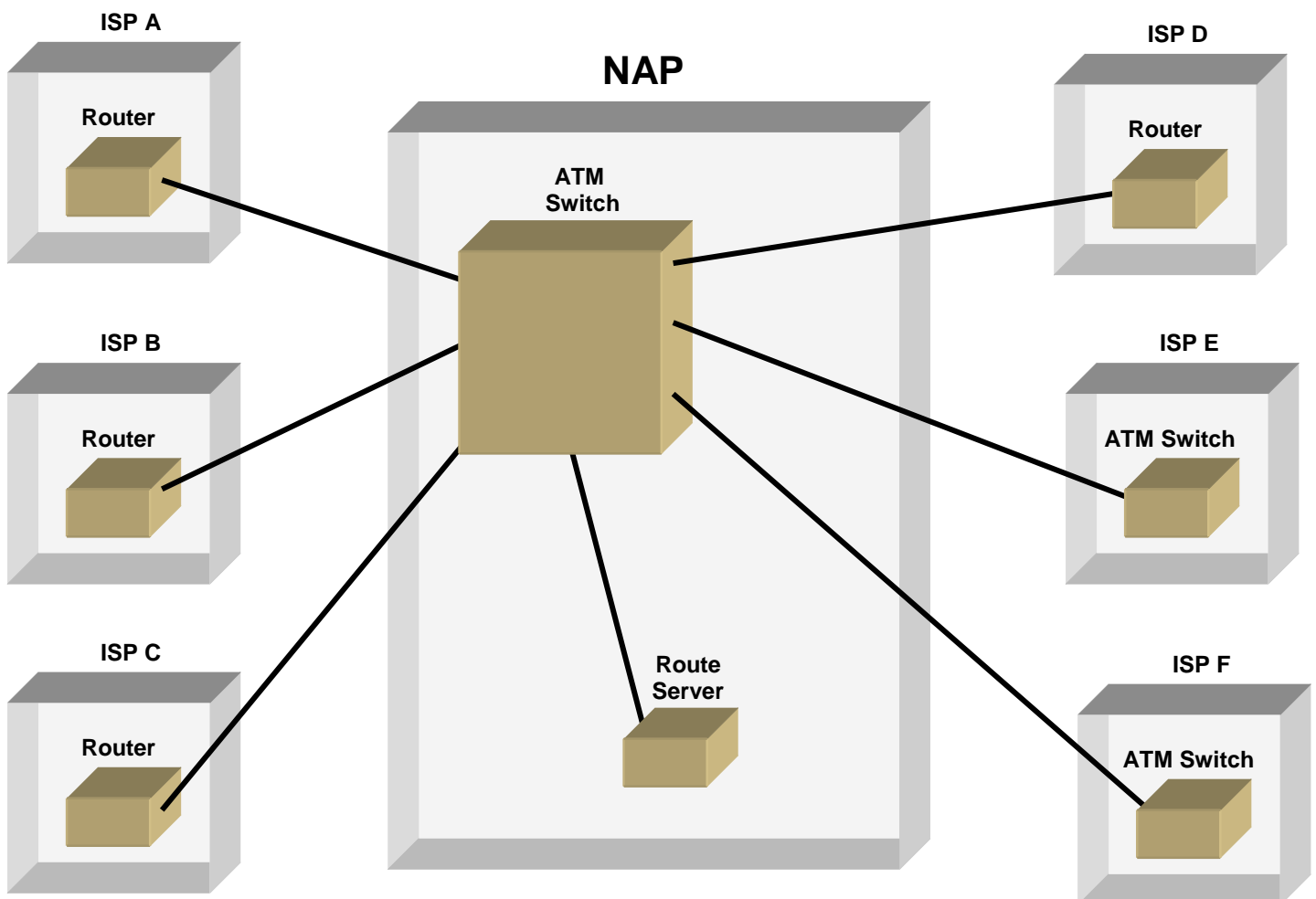

- All connections can be complex and packets sometimes travel long distances. Each local ISP might connect a different regional ISP, causing packets to flow between cities, even though their destination is to another local ISP within the same city.